



# ZE-Series, Electric Pumps

**ENERPAC**   
POWERFUL SOLUTIONS. GLOBAL FORCE.

▼ Shown from left to right: ZE3304ME-K, ZE4110DE-FHR



**Z** Tough.  
Dependable.  
Innovative.  
**CLASS**

**Assisted Return Pumps with Venturi Valve Technology**  
To improve productivity and plunger retraction, Enerpac offers valve configurations designed to accelerate your cylinder retraction speeds, ZE-Series pumps feature **Venturi Valve Technology** to facilitate the faster return of single-acting gravity return cylinders. See valve type in ordering matrix and details in section Directional Control Valves.

PUMP CONFIGURATIONS		Pump Type	Used with Tool or Cylinder		Valve Function <sup>1)</sup>			Valve <sup>1)</sup> Model Number	Useable Oil Capacity (litres)	
For options and other model numbers see ordering matrix or contact your Enerpac office. (For Z-Class pumps with air motor see ZA-series pumps on page 110).										
<b>No valve, without electric box <sup>2)</sup> or LCD</b> • For remote valves or pump mounting Enerpac VM-series valves.								–	4,0	
								–	10,0	
								–	20,0	
								–	40,0	
MANUAL VALVE CONTROL	<b>With manual valve, without electric box or LCD</b> • Ideal choice for most application • Manual valve control, for single and double-acting applications • Venturi Valve (VM33VAC) for faster retract of single-acting cylinders. • Manual motor control • On/Off switch on 1-phase electric motor.							VM32	4,0	
								VM33	8,0	
								VM33VAC	10,0	
								VM43	20,0	
								VM43L	40,0	
							VM43L	40,0		
MANUAL VALVE CONTROL	<b>With manual valve, with electric box and LCD</b> • For single-acting or double-acting applications • Venturi Valve Technology (VM33VAC) for faster retract of single-acting cylinders. • On/off switch on 1-phase electric motor • All options available.							VM32	4,0	
								VM32	8,0	
								VM33VAC	10,0	
								VM33L	10,0	
								VM43	20,0	
								VM43L	40,0	
REMOTE VALVE CONTROL	<b>With solenoid dump valve, with electric box and LCD</b> • Ideal for punching, crimping and cutting • For use when load holding is not required • Push-button pendant <sup>3)</sup> controls valve and motor • All options available.							VE32D	4,0	
								VE32D	8,0	
								VE32D	10,0	
								VE32D	20,0	
								VE32D	40,0	
	REMOTE VALVE CONTROL	<b>With solenoid 3-position valve, with electric box and LCD</b> • Ideal for production and lifting applications • 3-position valves (advance/hold/retract) • Venturi Valve Technology (VE33VAC) for faster retract of single-acting cylinders. • Push-button pendant <sup>3)</sup> controls valve and motor • All options available.							VE33	4,0
									VE33VAC	8,0
									VE33	10,0
									VE43	10,0
									VE43	20,0
						VE43	40,0			

<sup>1)</sup> See Valve Section (page 117) for hydraulic symbols and details.  
<sup>2)</sup> For No Valve, with Electric Box, see ordering matrix on page 103.  
<sup>3)</sup> Pendant includes 3 meters cord.



## ZE-Series, Electric Pumps

- High-efficiency pump design – higher oil flow and by-pass pressure
- High-strength, moulded electrical box protects electronics, power supplies and LCD readout and stands up to harsh industrial environments
- IP54 protection and isolation class
- Back-lit LCD provides self test, diagnostic and read-out capabilities never before offered on an industrial pump (included on pump with electric valves, optional on other models)
- Totally enclosed, fan-cooled industrial electric motors for extended life
- User adjustable relief valve built-in on manual and solenoid valves. Oil ports on valves are 3/8" NPTF
- Steel fan guard on all electric motors
- Full sight oil level glass on 10, 20 and 40 litres reservoirs, oil level indicators on 4 and 8 litres reservoirs.
- 40 micron filter breather with splash guard
- Durable steel reservoirs.

### ZE Series



Reservoir Capacity:  
**4 - 40 litres**

Flow at Rated Pressure:  
**0,55 - 2,73 l/min**

Motor Size:  
**0,75 - 5,60 kW**

Maximum Operating Pressure:  
**700 bar**

ZE3-Series 0,55 l/min at 700 bar Two-stage pump		ZE4-Series 0,82 l/min at 700 bar Two-stage pump		ZE5-Series 1,64 l/min at 700 bar Two-stage pump		ZE6-Series 2,73 l/min at 700 bar Two-stage pump	
Model Nr. <sup>4)</sup> 400V / 3 phase	(kg)	Model Nr. <sup>4)</sup> 400V / 3 phase	(kg)	Model Nr. <sup>4)</sup> 400V / 3 phase	(kg)	Model Nr. <sup>4)</sup> 400V / 3 phase	(kg)
ZE3004NW	36	ZE4004NW	40	-	-	-	-
ZE3010NW	45	ZE4010NW	49	ZE5010NW	54	ZE6010NW	72
ZE3020NW	57	ZE4020NW	61	ZE5020NW	66	ZE6020NW	84
ZE3040NW	80	ZE4040NW	84	ZE5040NW	89	ZE6040NW	107
ZE3204MW	39	ZE4204MW	43	-	-	-	-
ZE3308MW	44	ZE4308MW	48	-	-	-	-
ZE31010MW	51	ZE41010MW	55	ZE51010MW	60	ZE61010MW	78
ZE3420MW	60	ZE4420MW	64	ZE5420MW	69	ZE6420MW	87
ZE3840MW	85	ZE4840MW	89	ZE5840MW	94	ZE6840MW	112
ZE3204LW	42	ZE4204LW	46	-	-	-	-
ZE3208LW	47	ZE4208LW	51	-	-	-	-
ZE31010LW	52	ZE41010LW	56	ZE51010LW	61	ZE61010LW	79
ZE3610LW	53	ZE4610LW	57	ZE5610LW	62	ZE6610LW	80
ZE3420LW	63	ZE4420LW	67	ZE5420LW	72	ZE6420LW	90
ZE3840LW	88	ZE4840LW	92	ZE5840LW	97	ZE6840LW	115
ZE3104DW	44	ZE4104DW	48	-	-	-	-
ZE3108DW	49	ZE4108DW	53	-	-	-	-
ZE3110DW	53	ZE4110DW	57	ZE5110DW	62	ZE6110DW	79
ZE3120DW	65	ZE4120DW	69	ZE5120DW	74	ZE6120DW	92
ZE3140DW	88	ZE4140DW	92	ZE5140DW	97	ZE6140DW	115
ZE3304SW	49	ZE4304SW	53	-	-	-	-
ZE31108SW	55	ZE41108SW	59	-	-	-	-
ZE3310SW	58	ZE4310SW	62	ZE5310SW	67	ZE6310SW	85
ZE3410SW	58	ZE4410SW	62	ZE5410SW	67	ZE6410SW	85
ZE3420SW	70	ZE4420SW	74	ZE5420SW	79	ZE6420SW	97
ZE3440SW	93	ZE4440SW	97	ZE5440SW	102	ZE6440SW	120

<sup>4)</sup> See custom ordering matrix on page 95 for other voltages.



#### Adjustable Relief Valve

All VM and VE-Series have a user adjustable relief valve to allow the operator to easily set the optimum working pressure.



#### Locking Valves

For applications requiring positive load holding, VM-Series valves (except VM32) are available with a pilot-operated check valve. This provides hydraulic locking of the load until the valve is shifted into the retract position. To order this feature on your ZE-series pump see the valve type in the order matrix.

Page: 103



#### Single or Two-Stage

Choose **single-stage** pumps for applications that require constant flow regardless of pressure such as testing or clamping.

**Two-stage** pumps have an increased output flow at low pressure to allow fast movement towards the load, for reduced cycle times and increased productivity.



## ZE-Series, Options & Accessories

**ENERPAC**   
POWERFUL SOLUTIONS. GLOBAL FORCE.



### Electric Box <sup>1)</sup>

- Back-lit LCD
- Pump usage information, hour and cycle counts
- Low-voltage warning and recording
- Self-test and diagnostic capabilities
- Pressure read-out <sup>2)</sup>
- Auto-mode pressure setting <sup>2)</sup>
- Information can be displayed in six languages <sup>3)</sup>

<sup>1)</sup> Included on pumps with solenoid valves. Can be factory installed on pumps with manual valve.

<sup>2)</sup> When used with optional pressure transducer.

<sup>3)</sup> English, French, German, Italian, Spanish and Portuguese.



### Level/Temperature Switch <sup>4)</sup>

- Shuts down pump before oil level reaches an unsafe level, avoiding damage due to cavitation
- Shuts down pump when unsafe oil temperature is reached
- Ideal if pump is used in remote area without visual access to oil level.

<sup>4)</sup> 24 V, requires Electric Box. Available for 10, 20 and 40 litres reservoirs.

Accessory Kit Modelnr.	Fixed Temperature Signal (°C)	Operating Temperature (°C)	Max. Pressure (bar)
ZLS-U4 *	80	5 - 110	10

\* Add suffix **L** for factory installation.



### Return Line Filter

- 25 micron nominal filter removes contaminants from return oil flow before allowing it back into tank
- Internal by-pass valve prevents damage if filter is dirty
- With maintenance indicator
- Replaceable filter element PF25.

Accessory Kit Modelnr.	Maximum Pressure (bar)	Maximum Oil Flow (l/min)	By-pass Setting (bar)
ZPF *	13,8	45,4	1,7

\* Add suffix **F** for factory installation.



### Roll Cage

- For easy portability and hoisting
- Protects pump and electric box
- Available for all reservoir sizes.



### Skid Bar

- Provides easy two-hand lift
- Provides greater pump stability on soft or uneven surfaces.



### Foot Switch <sup>5)</sup>

- Hands-free remote control on solenoid dump and 3-position valves
- With 3 meters cord.

<sup>5)</sup> 15 V, requires Electric Box.

Accessory Kit Nr.	Fits on reservoir size:	(kg)
ZRC-04 *	4 and 8 litres <sup>5)</sup>	5,5
ZRC-04H *	4 and 8 litres <sup>6)</sup>	6,5
ZRB-10 *	10 litres	6,0
ZRB-20 *	20 litres	6,0
ZRB-40 *	40 litres	6,0

\* Add suffix **R** for factory installation.

<sup>5)</sup> For pump without heat exchanger

<sup>6)</sup> For pump with heat exchanger.

Accessory Kit Nr.	Fits on reservoir size:	(kg)
SBZ-4 *	4 and 8 litres <sup>5)</sup>	2,2
SBZ-4L *	4 and 8 litres <sup>6)</sup>	3,2

\* Add suffix **K** for factory installation.

Accessory Kit Nr.	Can be used on ZE-Series pumps with
ZCF-2 *	Solenoid VE-Series valves

\* Add suffix **U** for factory installation.

# ZE-Series, Options & Accessories



### Pressure Transducer <sup>1)</sup>

- Displays pressure on LCD in bar, MPa or psi
- More accurate than analog gauge
- Calibration can be fine-tuned for certification
- Easy-viewing variable rate display
- "Set pressure" feature turns off motor at user defined pressure <sup>2)</sup>.

<sup>1)</sup> 24 V, requires Electric Box.

<sup>2)</sup> Or shifts valve to neutral position on pump models with VE33 and VE43 solenoid valves.

Access-ory Kit Modelnr.	Adjustable Pressure Range (bar)	Switch-point repea-tability	Dead-band (bar)
ZPT-U4 *	3,5 - 700	± 0,5%	3,5

\* Add suffix **T** for factory installation.



### Pressure Switch <sup>3)</sup>

- Controls pump, monitors system
- Adjustable pressure 35-700 bar
- Includes glycerine filled 1000 bar pressure gauge G2536L
- Accuracy ± 1,5% of full scale.

<sup>3)</sup> 24 V, requires Electric Box. Not available in combination with pressure transducer. Not available on LCD-electronics.

Access-ory Kit Modelnr.	Switch-point repea-tability	Deadband (bar)	Oil Ports (NPTF)
ZPS-E3 *	± 2%	8 - 38	3/8"

\* Add suffix **P** for factory installation.



### Options

**Accessory Kits** can be installed by customer. See chart below for options on **Standard Electric** (without electric box) or **LCD Electric** (with electric box). Refer to page 103 for ordering matrix.

ZE-Series Options	Factory Installed		Accessory Kits	
	Std. Electr.	LCD Electr.	Std. Electr.	LCD Electr.
Return Line Filter	F	F	ZPF	ZPF
Skid Bar <sup>1)</sup>	K	K	SBZ	SBZ
Roll Cage	R	R	ZRB	ZRB
Single-stage	S	S	-	-
Heat Exchanger	-	H	-	ZHE
Pressure Gauge <sup>2)</sup>	G	G	-	-
Pressure Switch <sup>3)</sup>	-	P	-	ZPS-E3
Pressure Transducer <sup>4)</sup>	-	T	-	ZPT-U4
Level/Temp Switch <sup>5)</sup>	-	L	-	ZLS-U4
Foot Switch <sup>6)</sup>	-	U	-	ZCF-2

<sup>1)</sup> Available for 4 and 8 litres reservoirs.

<sup>2)</sup> Not available on pumps with pressure transducer.

<sup>3)</sup> Includes 1000 bar gauge. Only available on manual valves without locking feature.

<sup>4)</sup> Electric box can accept either pressure switch or pressure transducer, but not both.

<sup>5)</sup> Available for 10, 20 and 40 litres reservoirs.

<sup>6)</sup> For control of solenoid dump and 3-position valves.



### Pendants <sup>4)</sup>

- For pump types with valve operation "W" (No Valve, with Electric Box, without pendant).

<sup>4)</sup> When ordering Enerpac VE-Series solenoid valve the pendant must be ordered separately. Pendant connection to be plugged into electric box.

Pendant Model Nr.	To be used with solenoid valve:
ZCP-1	VE32D
ZCP-3	VE32, VE33, VE43



### Heat Exchanger <sup>5)</sup>

- Removes heat from by-pass oil to provide cooler operation
- Stabilizes oil viscosity, increasing oil life and reduces wear of pump and other hydraulic components.

Accessory Kit Nr.	Fits on reservoir size:	(kg)
ZHE-E04 *	4 and 8 litres	4,1
ZHE-E10 *	10, 20 and 40 litres	4,1

<sup>5)</sup> 24 VDC, requires electric box.

\* Add suffix **H** for factory installation.



### ZPT-U4 Pressure Transducer

More durable against mechanical and hydraulic shock than analog gauges.

- Digital pressure read-out provides accuracy of 0,5% of full scale.
- Easy-viewing variable rate display automatically varies increments between 3, 14, 35 and 145 bar as rate of pressure change increases.
- "Set pressure" feature turns off motor at user defined pressure (or shifts valve to neutral on VE33 and VE43 valves).



### ZHE-Series Heat Exchangers

Heat exchanger stabilizes oil temperature at 54 °C at 21 °C ambient temperature. Thermal transfer at 1,9 l/min and 21 °C ambient temperature: 900 Btu/hour [950 kJ].

Do not exceed max. oil flow of 26,5 l/min and max. pressure of 20,7 bar. Not suitable for water-glycol or high water based fluids.





Proudly Distributed By

**TRIDENT AUSTRALIA**  
FLUID SYSTEMS & COMPONENTS

# ZE-Series, Specifications & Dimensions

**ENERPAC**   
POWERFUL SOLUTIONS. GLOBAL FORCE.

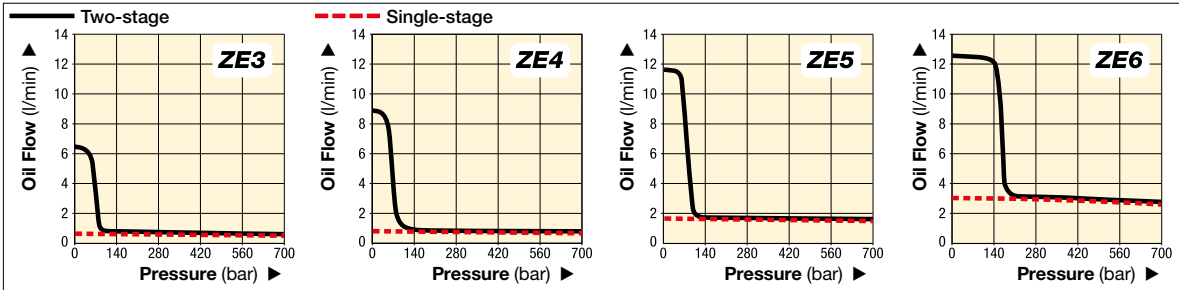

### ▼ ZE-SERIES PERFORMANCE CHART

Pump Series	Output Flow Rate at 50 Hz * (l/min)				Pump Unit	Available Reservoir Sizes (useable oil) (litres)	Motor Size (kW)	Relief Valve Adjustment Range (bar)	Sound Level (dBA)
	low pressure at 7 bar	low pressure at 50 bar	high pressure at 350 bar	high pressure at 700 bar					
ZE3	0,59	0,59	0,57	<b>0,55</b>	Single-stage	4-8-10-20-40	0,75	70-700	75
	6,15	5,26	0,57	<b>0,55</b>	Two-stage				
ZE4	0,87	0,87	0,84	<b>0,82</b>	Single-stage	4-8-10-20-40	1,12	70-700	75
	8,88	8,20	0,84	<b>0,82</b>	Two-stage				
ZE5	1,75	1,72	1,68	<b>1,64</b>	Single-stage	10-20-40	2,24	70-700	75
	11,61	11,27	1,68	<b>1,64</b>	Two-stage				
ZE6	3,00	2,94	2,86	<b>2,73</b>	Single-stage	10-20-40	5,60	70-700	80
	12,29	12,15	2,86	<b>2,73</b>	Two-stage				

\* Oil flow will be approximately 6/5 of these values at 60 Hz.



### Single or Two-Stage

Choose single-stage pumps for applications that require constant flow regardless of pressure such as testing or clamping. Two-stage pumps have an increased output flow at low pressure to allow fast movement towards the load, for reduced cycle times and increased productivity.

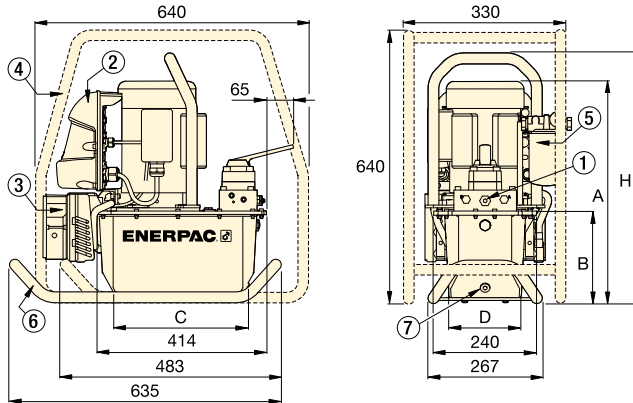

ZE-Series Pumps with 4 - 8 litres reservoir

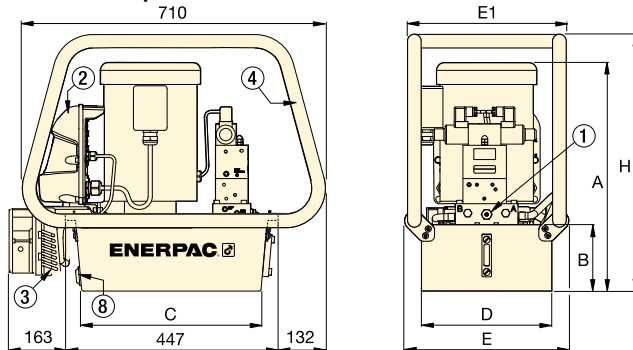

ZE-Series Pumps with 10 - 20 - 40 litres reservoir

- ① User adjustable relief valve on all manual and solenoid valves.  
3/8" NPTF on A and B ports;  
1/4" NPTF on auxiliary ports.
- ② Electric Box
- ③ Heat Exchanger
- ④ Roll Cage
- ⑤ Return Line Filter
- ⑥ Skid Bar
- ⑦ Magnetic Oil Drain
- ⑧ Oil Drain / Oil Level/Temperature Switch

Reservoir Size (useable oil in litres)	ZE-Series Pump Dimensions (mm)						
	A	B	C	D	E	E1	H
4,0	457	143	279	152	-	-	513
8,0	457	143	279	206	-	-	513
10,0	533	158	419	305	384	371	600
20,0	558	180	419	422	501	488	625
40,0	648	270	399	505	576	572	715

## ZE-Series, Pump Ordering Matrix

▼ This is how ZE-Series pump model numbers are built up:

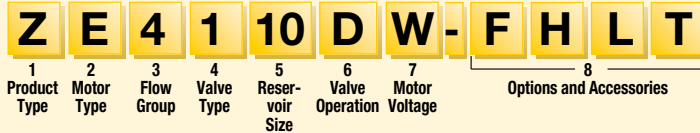

### 1 Product Type

**Z** = Pump Class

### 2 Prime Mover

**E** = Induction electric motor

### 3 Flow Group

- 3** = 0,55 l/min @ 700 bar (0,75 kW)
- 4** = 0,82 l/min @ 700 bar (1,12 kW)
- 5<sup>1)</sup>** = 1,64 l/min @ 700 bar (2,24 kW)
- 6<sup>1)</sup>** = 2,73 l/min @ 700 bar (5,60 kW)

### 4 Valve Type

- 0** = No valve, with cover plate
- 1** = 3/2 Dump valve **VE32D**
- 2** = 3/2 manual **VM32**
- 3** = 3/3 manual **VM33** or electric **VE33**
- 4** = 4/3 manual **VM43** or electric **VE43**
- 6** = 3/3 manual locking valve **VM33L** with pilot operated check.
- 8** = 4/3 manual locking valve **VM43L** with pilot operated check.
- 9** = 4 way/3 position manual with power seating (**VM43-LPS**)
- 10** = 3 way/3 position manual **Venturi** valve (**VM33VAC**)
- 11** = 4 way/3 position electric **Venturi** valve (**VE33VAC**)
- 12** = 3 way/3 position manual locking **Venturi** valve (**VM33LVAC**)

### 8 Options and Accessories

- F** = Return Line Filter
- G<sup>6)</sup>** = 1000 bar gauge
- H<sup>7)</sup>** = Heat exchanger
- K** = Skid Bar (only on 4 and 8 litres)
- L<sup>7)</sup>** = Oil Level/Temperature Switch<sup>8)</sup>
- N** = No reservoir handles (includes lifting eyes)
- P<sup>7)</sup>** = Pressure Switch (only available on manual valves without locking feature)
- R** = Roll Cage
- S** = Single-stage pump unit
- T<sup>7)</sup>** = Pressure transducer<sup>9)</sup>
- U<sup>7)</sup>** = Foot Switch

<sup>1)</sup> ZE5 and ZE6-Series only available with 3-phase electric motors.

<sup>2)</sup> 4 and 8 litres only available on ZE3 and ZE4-Series.

<sup>3)</sup> 1-phase motors only available on ZE3 and ZE4-Series

<sup>4)</sup> 208-240V, 1 ph with European plug EMC directive compliant.

<sup>5)</sup> Models with 3-ph motors without Electric Box shipped without cord, motor starter or overload protection.

<sup>6)</sup> Not available on pumps with pressure transducer (T).

<sup>7)</sup> Requires Electric Box.

<sup>8)</sup> Not available on 4 and 8 litres reservoir.

<sup>9)</sup> Provides digital pressure read-out on LCD-display of electric box.

<sup>10)</sup> When using solenoid valve on valve type "W" order optional pendant.

All Z-Class electric pumps comply with TÜV and CE requirements.



## ZE Series



Reservoir Capacity:

**4 - 40 litres**

Flow at Rated Pressure:

**0,55 - 2,73 l/min**

Motor Size:

**0,75 - 5,60 kW**

Maximum Operating Pressure:

**700 bar**



### How to Order Single-Stage Pumps

To specify a single-stage pump, place the letter "S" at the end of the model number. For example:

#### ZE4210ME-S

ZE4-Series pump, oil flow 0,82 l/min at 700 bar, VM32 manual valve, 10 litres reservoir, without electrical box, without pendant, 240 Volt 1-phase electric motor and single-stage pump unit.



### Assisted Return Pumps

To improve productivity and plunger retraction, Enerpac offers valve configurations designed to accelerate your cylinder retraction speeds, ZU4 and ZE-Series pumps feature **Venturi Valve Technology** to facilitate the faster return of single-acting gravity and spring return cylinders. See valve type in ordering matrix and details in section Directional Control Valves.