



# ZA4-Series, Modular Air Hydraulic Pumps

**ENERPAC**  
POWERFUL SOLUTIONS. GLOBAL FORCE.

▼ Shown: ZA4208MX, ZA4420MX



**Z** Tough  
Dependable  
Innovative  
**CLASS**



**ATEX 95 Certified**

The Enerpac ZA4-series air pumps are tested and certified according to the **Equipment Directive 94 / 9 / EC "ATEX Directive"** for equipment and protective systems intended for use in potentially explosive atmospheres.



Page: 263

- ATEX 95 certified for use in potentially explosive atmospheres
- Features Z-Class high efficiency pump design, higher oil flow and bypass pressure
- Two-speed operation reduces cycle time for improved productivity
- User adjustable relief valve built-in on manual valves. Oil ports on valves are 3/8" NPTF
- Optional heat exchanger warms exhaust air to prevent freezing and cools the oil
- Full sight oil level glass on 10, 20 and 40 litres reservoirs, oil level indicators on 4 and 6,6 litres reservoirs.



**Speed Chart**

To determine how a specific pump will operate your cylinder, see the Pump-Cylinder Speed Chart in the 'Yellow Pages'.

Page: 273



**Hoses**

Enerpac offers a complete line of high quality hydraulic hoses. To ensure the integrity of your system, specify only genuine Enerpac hydraulic hoses.

Page: 122

Used with Cylinder	Usable Oil Capacity (litres)	Manual Valve <sup>1)</sup> Model Number	Valve Function	Model Number	Output Flow Rate <sup>2)</sup>				Relief Valve Adjustment Range (bar)	Maximum Air Consumption <sup>3)</sup> (l/min)
					at 7 bar	at 50 bar	at 350 bar	at 700 bar		
-	4,0	-	-	ZA4004NX	14,0	11,0	1,8	1,3	-	2840
Single-acting	4,0	VM32	Advance / Retract	ZA4204MX	14,0	11,0	1,8	1,3	70 - 700	2840
	6,6	VM33	Advance / Hold /Retract	ZA4308MX	14,0	11,0	1,8	1,3	70 - 700	2840
	10,0	VM33L	Advance / Hold /Retract	ZA4610MX	14,0	11,0	1,8	1,3	70 - 700	2840
Double-acting	4,0	VM43	Advance / Hold /Retract	ZA4404MX	14,0	11,0	1,8	1,3	70 - 700	2840
	6,6	VM43	Advance / Hold /Retract	ZA4408MX	14,0	11,0	1,8	1,3	70 - 700	2840
	10,0	VM43L	Advance / Hold /Retract	ZA4810MX	14,0	11,0	1,8	1,3	70 - 700	2840
	20,0	VM43	Advance / Hold /Retract	ZA4420MX	14,0	11,0	1,8	1,3	70 - 700	2840
	40,0	VM43	Advance / Hold /Retract	ZA4440MX	14,0	11,0	1,8	1,3	70 - 700	2840

<sup>1)</sup> See pages 116-117 for hydraulic symbols of these valves.

<sup>2)</sup> Actual oil flow will vary with air supply.

<sup>3)</sup> Dynamic air pressure range: 4 - 7 bar.



Proudly Distributed By

**TRIDENT AUSTRALIA**  
FLUID SYSTEMS & COMPONENTS

## Modular Air Hydraulic Pumps

▼ This is how a ZA4-Series pump model number is built up:



### 1 Product Type

**Z** = Pump Class

### 2 Prime Mover

**A** = Air motor

### 3 Flow Group

**4** = 1,3 l/min @ 700 bar

### 4 Valve Type

- 0** = No valve, with cover plate
- 2** = 3/2 manual valve VM32
- 3** = 3/3 manual valve VM33
- 4** = 4/3 manual valve VM43
- 6** = 3/3 manual locking valve VM33L with pilot operated check
- 7** = 3/2 manual valve VM22
- 8** = 4/3 manual locking valve VM43L with pilot operated check.

### 5 Reservoir Size, useable oil

- 04** = 4 litres
- 08** = 6,6 litres
- 10** = 10 litres
- 20** = 20 litres
- 40** = 40 litres

### 6 Valve Operation

- M** = Manual valve
- N** = No valve

### 7 Motor Voltage

- X** = Not applicable

### 8 Options

- F** = Return Line Filter
- G** = 1000 bar gauge
- H** = Heat exchanger (on 4 and 6,6 litres reservoir only)
- K** = Skid Bar (on 4 and 6,6 litres reservoir only)
- N** = No reservoir handles (includes lifting eyes on 10, 20 and 40 litres)
- R** = Roll Cage

### Ordering Example

Model Number: **ZA4208MX-FHK**  
ZA4208MX-FHK is an air operated pump with a 3-way, 2-position manual valve, 6,6 litres reservoir, filter, heat exchanger and skid bar.

## ZA4 Series



Reservoir Capacity:

**4 - 40 litres**

Flow at Rated Pressure:

**1,3 l/min**

Air Consumption:

**2840 l/min**

Maximum Operating Pressure:

**700 bar**

- ① User adjustable relief valve on all manual valves. 3/8" NPTF on A and B ports; 1/4"NPTF on auxiliary ports.
- ② Air inlet 1/2" NPTF
- ③ Return Line Filter (optional)
- ④ Oil Sight Gauge
- ⑤ Roll Cage (optional)
- ⑥ Oil Drain
- ⑦ Lifting eyes (optional)
- ⑧ Handles
- ⑨ Skid Bar (Modelnr. SBZ-4) (optional)

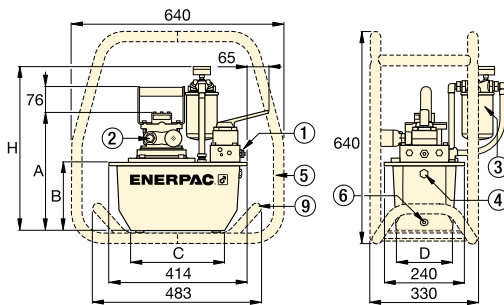

ZA4-Series Pumps with 4 - 6,6 litres reservoir

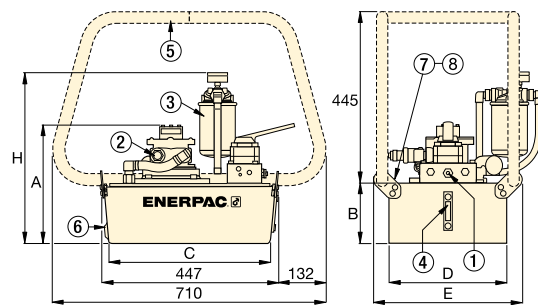

ZA4-Series Pumps with 10, 20 and 40 litres reservoir

Sound Level (dBA)	Motor Size (kW)	Dimensions (mm)							Model Number
		A	B	C	D	E	H		
80 - 95	3,0	295	142	279	152	-	429	27	<b>ZA4004NX</b>
80 - 95	3,0	295	142	279	152	-	429	30	<b>ZA4204MX</b>
80 - 95	3,0	356	203	279	205	-	490	34	<b>ZA4308MX</b>
80 - 95	3,0	330	180	414	421	500	467	51	<b>ZA4610MX</b>
80 - 95	3,0	295	142	279	152	-	429	31	<b>ZA4404MX</b>
80 - 95	3,0	356	203	279	205	-	490	35	<b>ZA4408MX</b>
80 - 95	3,0	305	155	419	305	384	442	40	<b>ZA4810MX</b>
80 - 95	3,0	330	180	414	421	500	467	52	<b>ZA4420MX</b>
80 - 95	3,0	419	269	399	505	584	556	75	<b>ZA4440MX</b>

