

## SG1 SERIES

## Regulators - Pressure Reducing

DSG012031X012

## Specifications

For questions about this product, please consult TESCO.

## OPERATING PARAMETERS

Pressure rating per criteria of CGA E-4; ASME B31; ASME BPVC

## Maximum Inlet Pressure

**C<sub>v</sub> = 0.06:** 4500 psig / 310 bar

**C<sub>v</sub> = 0.2:** 3000 psig / 207 bar

## Maximum Outlet Pressure

15, 25, 50, 125, 250 psig

103, 172, 345, 862, 1724 kPa

1.0, 1.7, 3.4, 8.6, 17.2 bar

## Design Proof Pressure

150% maximum rated

## Leakage

**Internal:** Bubble-tight

**External:** Designed to meet

$< 2 \times 10^{-8}$  atm cc/sec He /  $< 2 \times 10^{-8}$  mbar l/s He

## Operating Temperature

PCTFE seat: -40°F to 140°F / -40°C to 60°C

Polyimide\* seat: -40°F to 250°F / -40°C to 121°C

## Flow Capacity

C<sub>v</sub> = 0.06, 0.2

## MEDIA CONTACT MATERIALS

## Body

316L Stainless Steel, Nickel-Plated Brass

## Seat

PCTFE, Polyimide\*

## Diaphragm

316L Stainless Steel, Neoprene

## Filter

10 micron nominal sintered Bronze

10 micron nominal sintered 316 Stainless Steel

## Seal

PTFE or Nitrile, Buna-N

## Remaining Parts

Brass, 300 Series Stainless Steel

## OTHERS

## Connections

Inlet and outlet: 1/4" NPTF

Accessories: 1/4" NPTF

## Cleaning

CGA 4.1 and ASTM G93

## Weight

2.4 lbs / 1.1 kg

Teflon® and Vespel® are registered trademarks of E.I. du Pont de Nemours and Company. Meldin® is a registered trademark of Saint-Gobain.

\*Per ASTM D 6456-99 Type II Class 1M (Meldin® 7021 or Vespel® SP-21)

## NOTE:

When choosing a regulator and control pressure, decaying inlet characteristic must be considered when the supply pressure is expected to change. The decaying inlet characteristic of a pressure reducing regulator is commonly known as the increase in control pressure due to the decrease in supply pressure. It is important to make sure this effect does not cause the control pressure to exceed the pressure rating of the unit's outlet or that of the downstream system.

For more information on decaying inlet, please refer to the Technical Information section of the product catalog and/or contact the TESCO customer support further assistance.



TESCOM SG1 Series is a compact, lightweight high purity single-stage regulator for specialty and industrial gases. Sensitive, extra long-life metal diaphragm ensures gas purity and integrity. User-friendly model number enables the specifier to select optional gauges, relief and shut-off valves, and cylinder connections as part of the regulator assembly.

## Applications

- Laboratory and Point-of-Use Gas Systems in medical, pharmaceutical, food and beverage, and other high purity applications
- Process analyzer gases, metal fabrication and specialty and industrial gas cylinders

## Features and Benefits

- Cartridge valve design incorporates a 10 micron filter that protects the regulator seat and makes service simple
- Optional neoprene diaphragm provides exceptional sensitivity for precise pressure control



Proudly Distributed By

**TRIDENT** AUSTRALIA  
FLUID SYSTEMS & COMPONENTS

## SG1 SERIES

### SG1 Series Regulator Drawing

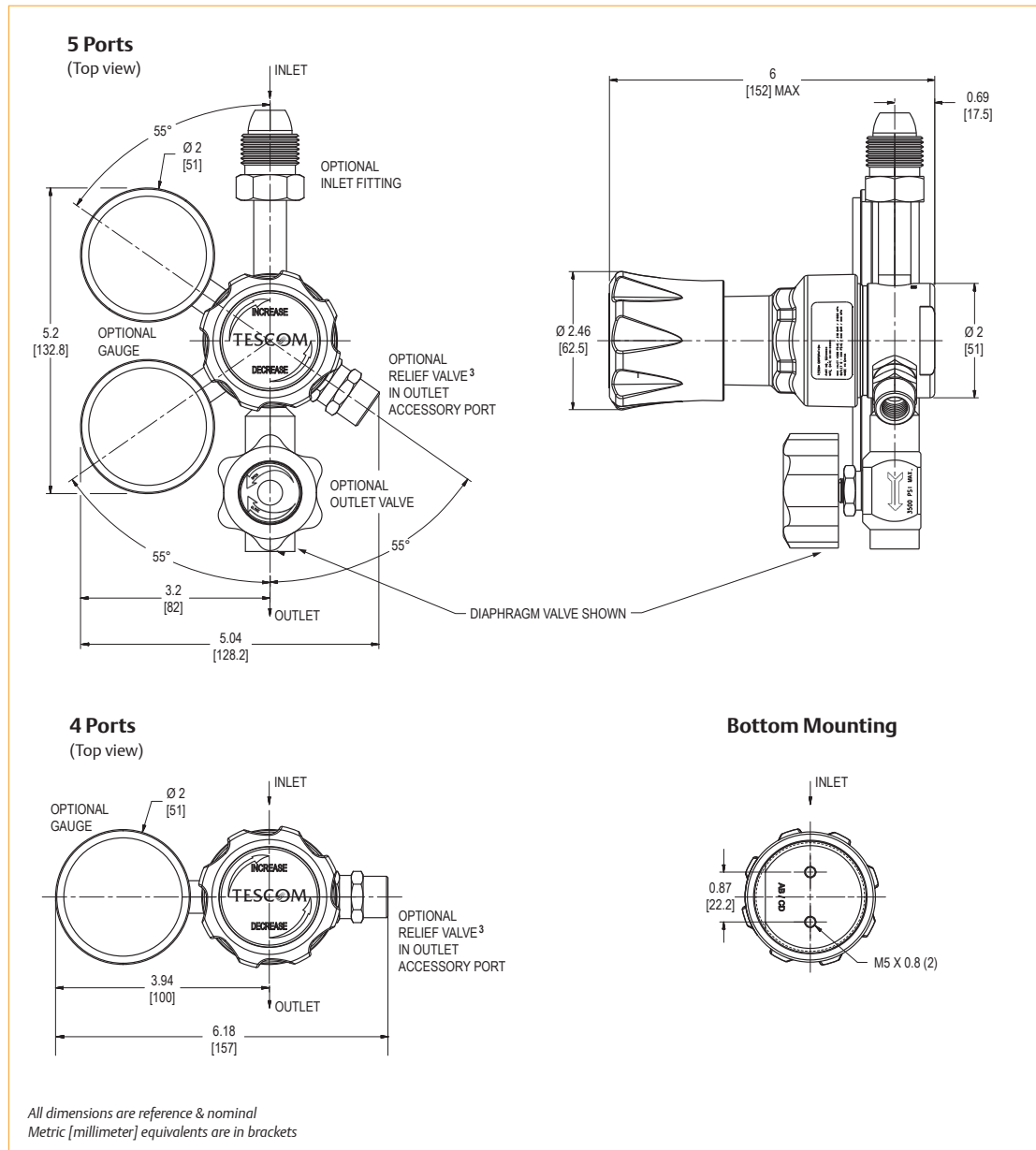



**SG1 SERIES**

**SG1 Series Regulator Flow Charts**

For more information on how to read flow curves, please refer to the Flow Curves and Calculations document (debul2007x012) in the TESCOM catalog or on [www.tescom.com](http://www.tescom.com).

**C<sub>v</sub> = 0.06 Model**

**Metal Diaphragm**

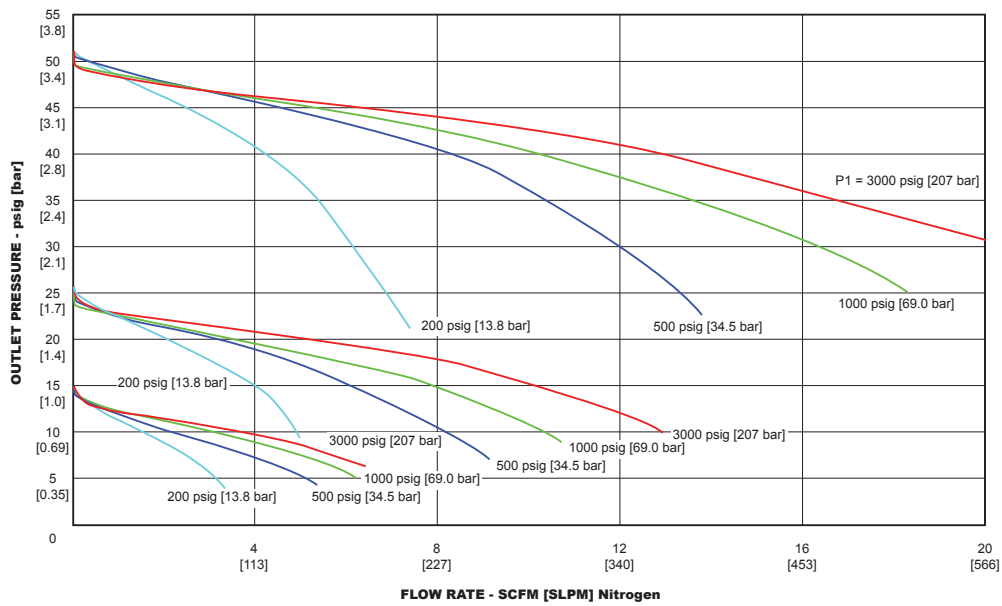
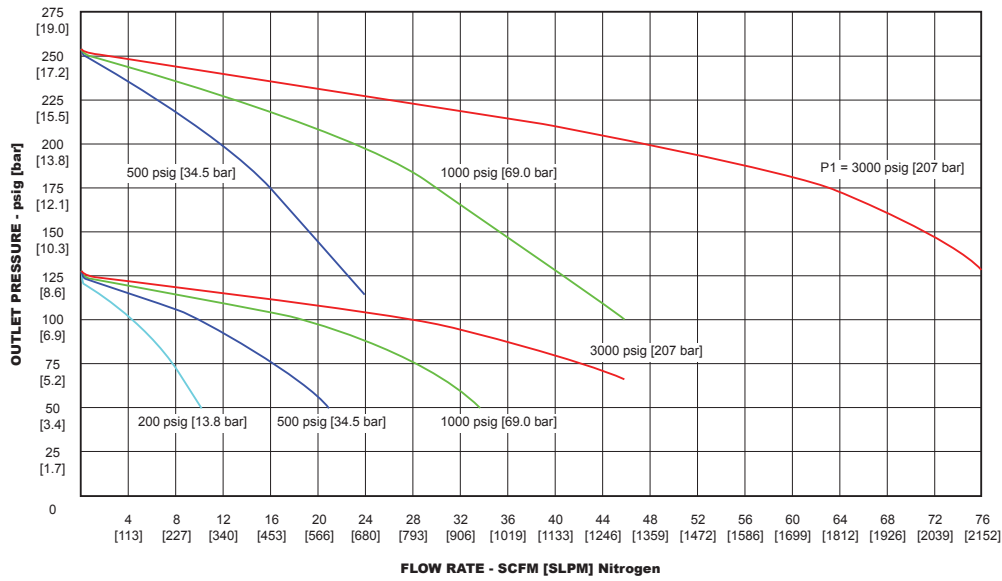



Proudly Distributed By

**TRIDENT** AUSTRALIA  
FLUID SYSTEMS & COMPONENTS

## SG1 SERIES

### SG1 Series Regulator Flow Charts

For more information on how to read flow curves, please refer to the Flow Curves and Calculations document (debul2007x012) in the TESCOM catalog or on [www.tescom.com](http://www.tescom.com).

**C<sub>v</sub> = 0.06 Model**

**Neoprene Diaphragm**

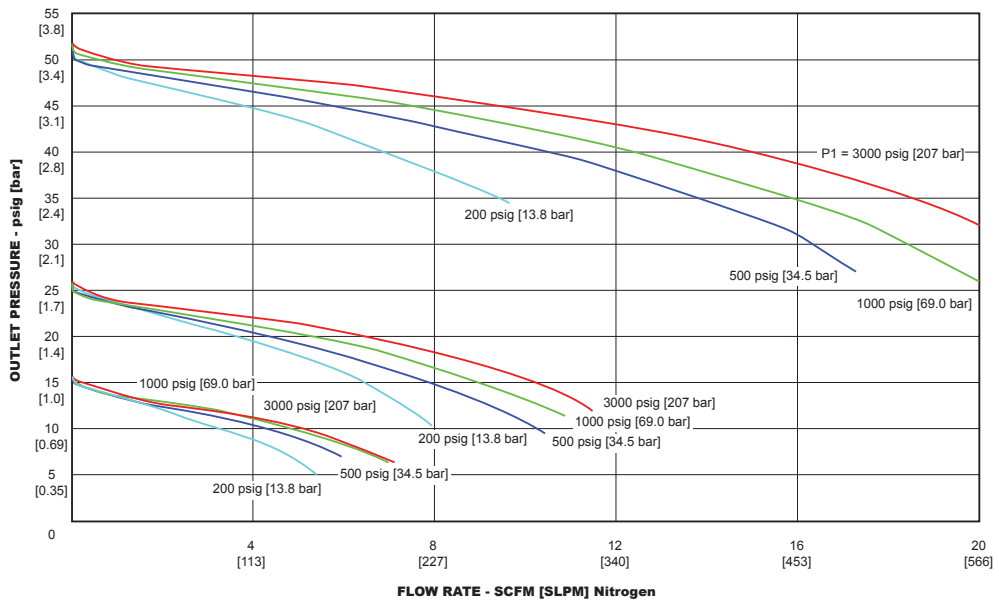
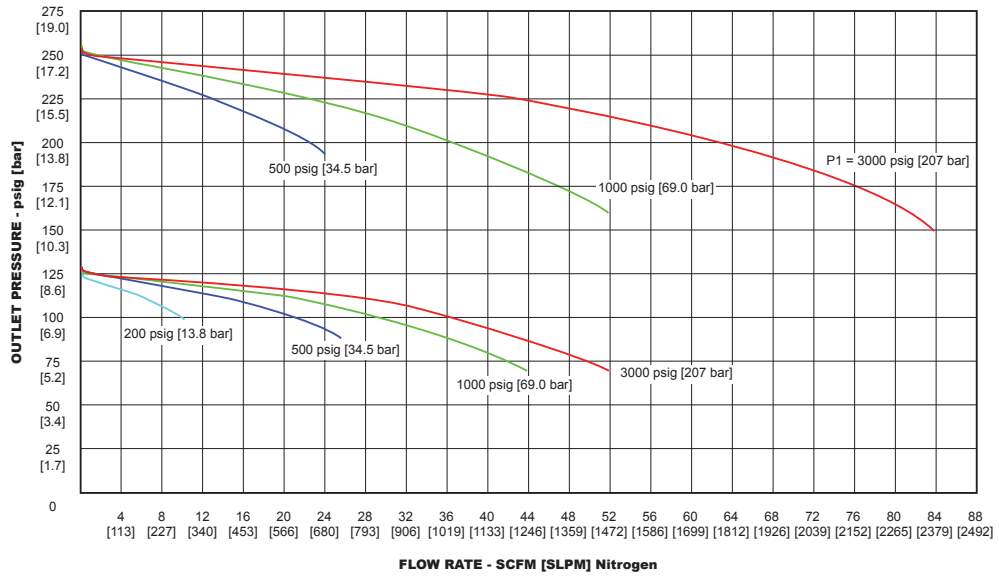

330 **EMERSON**

Visit our website at [emerson.com](http://emerson.com) or contact us at (800) 447-1250

**TESCOM**

SG1 SERIES

SG1 Series Regulator Flow Charts

For more information on how to read flow curves, please refer to the Flow Curves and Calculations document (debul2007x012) in the TESCOM catalog or on [www.tescom.com](http://www.tescom.com).

$C_v = 0.20$  Model

Metal Diaphragm

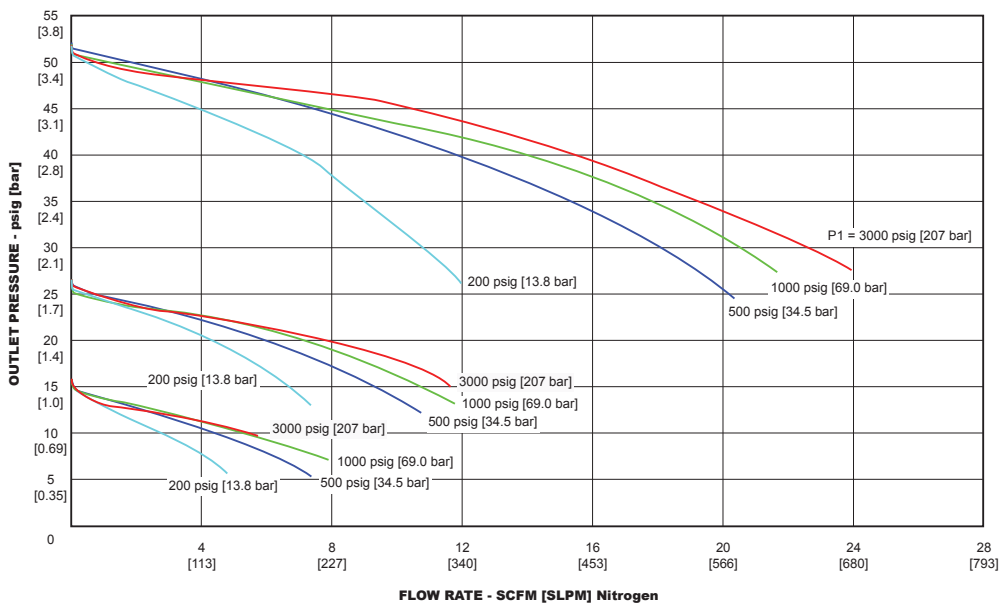
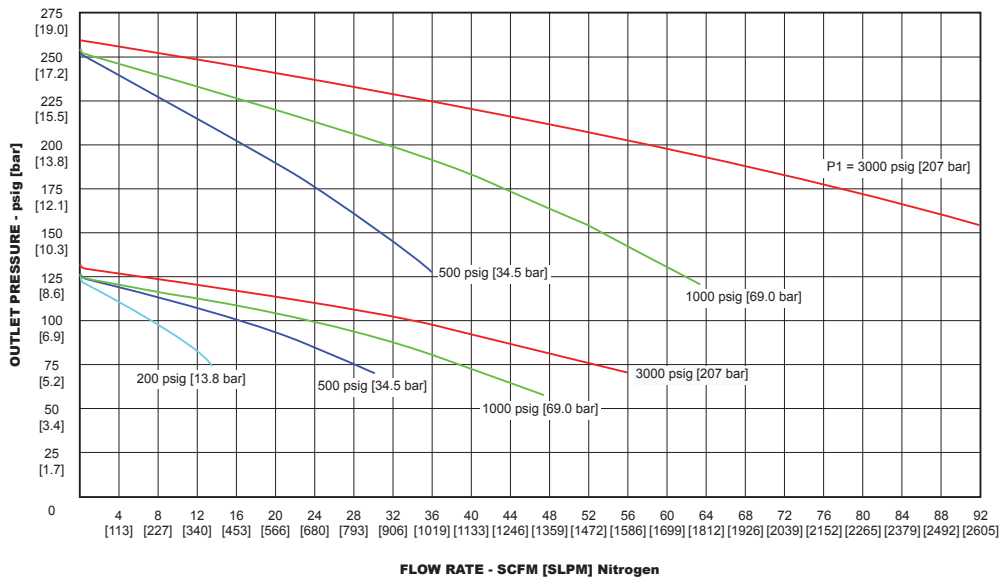



Proudly Distributed By

TRIDENT AUSTRALIA  
FLUID SYSTEMS & COMPONENTS

## SG1 SERIES

### SG1 Series Regulator Flow Charts

For more information on how to read flow curves, please refer to the Flow Curves and Calculations document (debul2007x012) in the TESCOM catalog or on [www.tescom.com](http://www.tescom.com).

$C_v = 0.20$  Model

Neoprene Diaphragm

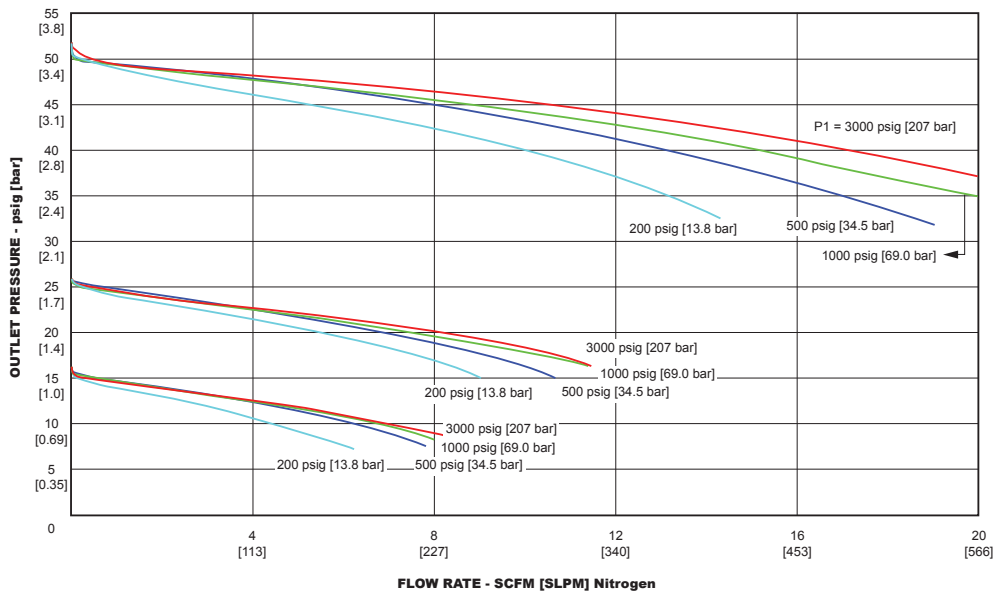
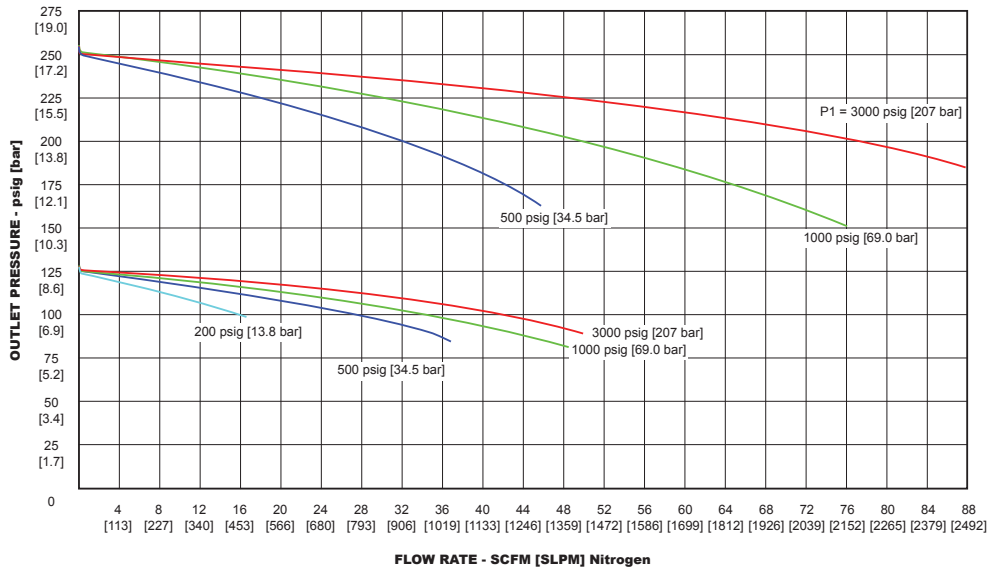



Proudly Distributed By

**TRIDENT AUSTRALIA**  
FLUID SYSTEMS & COMPONENTS

## SG1 SERIES

### SG1 Series Regulator Part Number Selector

Repair Kits, Accessories & Modifications may be available for this product. Please contact TESCOM for more information.

#### Base Model

Example for selecting a part number:

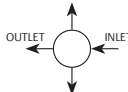
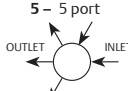
SG1	6	3	1	4	1	[Blank]		
BASIC SERIES	BODY MATERIAL	OUTLET PRESSURE RANGES	DIAPHRAGM MATERIAL	SEAL MATERIAL	PORTS (TOP VIEW)	FLOW C <sub>v</sub>	P1	SEAT MATERIAL
SG1	P – Nickel-Plated Brass 6 – 316L Stainless Steel	1 – 15 psig / 103 kPa / 1.0 bar <sup>1</sup> 2 – 25 psig / 172 kPa / 1.7 bar 3 – 50 psig / 345 kPa / 3.4 bar 4 – 125 psig / 862 kPa / 8.6 bar 5 – 250 psig / 1724 kPa / 17.2 bar	1 – 316L Stainless Steel 2 – Neoprene	PTFE Nitrile, Buna-N	4 – 4 port  5 – 5 port 	1 – 0.06 2 – 0.2	4500 psig 31,026 kPa 310 bar 3000 psig 20,684 kPa 207 bar	[Blank] – PCTFE V – Polyimide <sup>2</sup>
<p>1. Consider a two-stage regulator (SG2) if using full range of inlet pressure capabilities 2. Per ASTM D 6456-99 Type II Class 1M (Meldin® 7021 or Vespel® SP-21)</p>								

#### Accessories

Extension to base model part number:

SG1XXXXXX – 06 A 1 A

BASE MODEL NUMBER	CYLINDER CONNECTIONS	GAUGES <sup>4</sup>	RELIEF VALVE <sup>3</sup>	OUTLET VALVE
00 – None 01 – CGA 296 02 – CGA 350 03 – CGA 510 04 – CGA 540 05 – CGA 580 06 – CGA 590 07 – CGA 660 08 – DIN 477-1.1 09 – DIN 477-1.3 10 – DIN 477-1.5 11 – DIN 477-1.6 12 – DIN 477-1.7 13 – DIN 477-1.8 14 – DIN 477-1.9 15 – DIN 477-1.10 16 – DIN 477-1.14 17 – DIN 477-5.54 18 – DIN 477-5.57 19 – BS 341 (2002) #02 20 – BS 341 (2002) #03 21 – BS 341 (2002) #04 22 – BS 341 (2002) #06 23 – BS 341 (2002) #07 24 – BS 341 (2002) #08 25 – BS 341 (2002) #10 26 – BS 341 (2002) #11 27 – BS 341 (2002) #13 28 – BS 341 (2002) #14 29 – BS 341 (2002) #15	0 – None P – Plug(s) A – psi / kPa B – bar / psi	A – None P – Plug 1 – PTFE Pipe-away	0 – None A – Diaphragm valve B – Needle valve	
<p>Note: Cylinder connections are available in all world areas.</p>				

3. The relief valve is not intended to be a "Pressure Relief Device" as defined by ASME Boiler & Pressure Vessel Code - Section VIII, nor is it intended to be a "Safety Accessory" or "Pressure Limiting Device" as defined by the Pressure Equipment Directive (2014/68/EU). The relief valve is intended to indicate a potential problem with the regulator and prevent further damage to the regulator. The relief valve is not intended to protect the downstream process equipment.

#### <sup>4</sup>GAUGE PRESSURE RANGES

OUTLET PRESSURE RANGE	OUTLET GAUGE PRESSURE RANGE
SG1X1XXXX – 15 psig / 103 kPa / 1.0 bar	0-30 psig / 200 kPa / 2 bar
SG1X2XXXX – 25 psig / 172 kPa / 1.7 bar	0-30 psig / 200 kPa / 2 bar
SG1X3XXXX – 50 psig / 345 kPa / 3.4 bar	0-60 psig / 400 kPa / 4 bar
SG1X4XXXX – 125 psig / 862 kPa / 8.6 bar	0-160 psig / 1100 kPa / 11 bar
SG1X5XXXX – 250 psig / 1724 kPa / 17.2 bar	0-300 psig / 2000 kPa / 20 bar
INLET PRESSURE RANGE	INLET GAUGE PRESSURE RANGE
All	6000 psig / 41,000 kPa / 400 bar

TESCOM

Visit our website at [emerson.com](http://emerson.com) or contact us at (800) 447-1250

 **EMERSON** 333

## SG1 SERIES

### SG1 Series Rebuild Kits

*Rebuild Kits include replacement cartridges, diaphragms, diaphragm seals, lubrication and instruction sheet.*

KIT PART NUMBER	FOR SG PART NUMBER
JT389-8927	SG1PX1X1
JT389-8928	SG1PX1X2
JT389-8929	SG1PX2X1
JT389-8930	SG1PX2X2
JT389-8931	SG16X1X1
JT389-8932	SG16X1X2
JT389-8933	SG16X2X1
JT389-8934	SG16X2X2
JT389-8927V	SG1PX1X1V
JT389-8928V	SG1PX1X2V
JT389-8929V	SG1PX2X1V
JT389-8930V	SG1PX2X2V
JT389-8931V	SG16X1X1V
JT389-8932V	SG16X1X2V
JT389-8933V	SG16X2X1V
JT389-8934V	SG16X2X2V