



## RT-Series, Telescopic Cylinders

**ENERPAC**   
POWERFUL SOLUTIONS. GLOBAL FORCE.

▼ RT-2111 Telescopic Cylinder (shown with plunger extended and retracted)



### Moving a load a greater distance

- Nitrocarburized surface treatment inside and out provides corrosion protection
- 3% side-load of full capacity
- Double or triple wear bearings support lifting stages
- Tilting saddles with 5 degrees of maximum tilt standard on all models
- Design Safety factor complies with ASME B30.1 & EN1494
- Lifting eyes for safe handling and positioning
- CR-400 coupler for compatibility with standard product
- Steel cylinder base for maximum strength.



#### RT-Series, Multi-Stage Cylinders

Enerpac compact, multi-stage telescopic cylinders are available with two or three pistons, and can lift loads up to 600 mm in a single movement.

Nitrocarburized surface treatment inside and out provides unparalleled sideload resistance and corrosion protection for safe use in the harshest conditions. The longer stroke length of telescopic cylinders will save you time and simplify projects by moving a load a greater distance and eliminating the use of temporary cribbing.



#### Tilt Saddles

All RT-Series cylinders include integral tilt saddles with maximum tilt angles up to 5 degree.



◀ The longer stroke length of telescopic cylinders will save you time and simplify projects by moving a load a greater distance and eliminating the use of temporary cribbing.

Cylinder Capacity at Maximum Stroke ton (kN)	Maximum Stroke (mm)	Model Number	Collapsed Height (mm)	Extended Height (mm)
14,0 (137)	270	RT-1510	283	553
	435	RT-1817	345	780
20,2 (198)	300	RT-2111	317	617
	500	RT-2119	395	895
31,5 (309)	300	RT-3311	352	652
	600	RT-3323	476	1076

## Multi-Stage Telescopic Cylinders, Single-Acting, Load Return

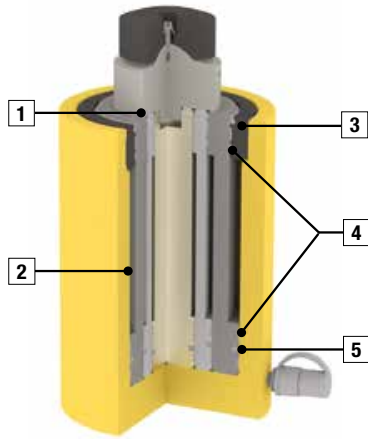

- 1 Wiper Ring** on each stage to minimize contamination.
- 2 Nitrocarburized Coating** for maximum corrosion protection and surface hardness. Exterior in nitrided and Enerpac yellow epoxy.
- 3 Stop Ring** full load capable to prevent plunger overstroke.
- 4 Wear Bearings.** Double or triple wear bearings for maximum sideload capability and wear resistance.
- 5 Seals** for maximum compliance and high wear resistance.

### RT Series



Capacity:  
**14 - 31 ton**

Stroke:  
**270 - 600 mm**

Maximum Operating Pressure:  
**700 bar**

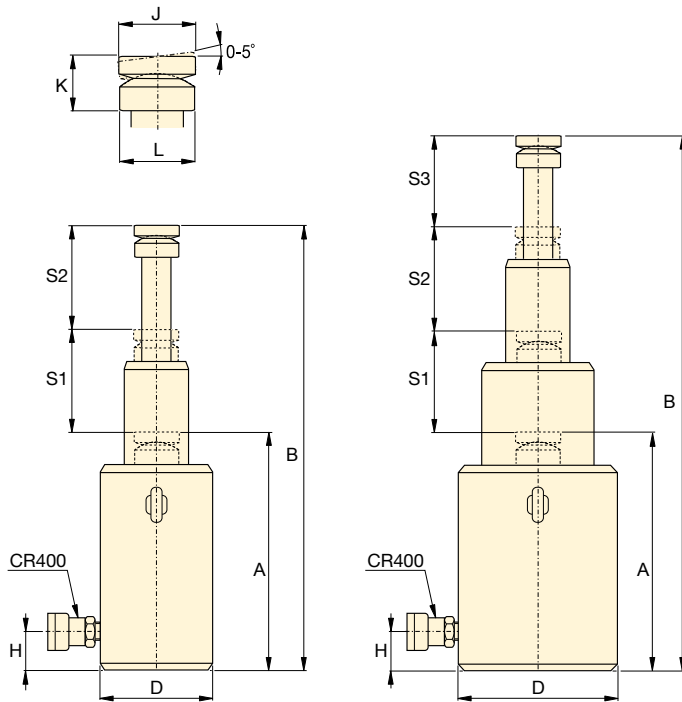

#### Multi-Stage Cylinders

- 1st Stage:** maximum load capacity at lowest maximum stroke
- 2nd Stage:** extended stroke but at lower maximum capacity than the 1st stage
- Final Stage:** maximum stroke extension but lowest maximum capacity.



#### Hoses

Enerpac offers a complete line of high quality hydraulic hoses. To ensure the integrity of your system, specify only Enerpac hydraulic hoses.

Page: **122**

Oil Capacity (cm <sup>3</sup> )	1st Stage		2nd Stage		3rd Stage		Outside Diameter D (mm)	Bottom to Advance Port H (mm)	Saddle Diameter J (mm)	Saddle Height K (mm)	Saddle Support Diameter L (mm)	Model Number	
	Capacity ton (kN)	Stroke S1 (mm)	Capacity ton (kN)	Stroke S2 (mm)	Capacity ton (kN)	Stroke S3 (mm)							
944	36 (352)	135	14 (137)	135	–	–	110	20	60	49	60	15,1	RT-1510
3092	95 (929)	145	41 (397)	145	17 (166)	145	170	27	80	73	85	40,3	RT-1817
1487	51 (496)	150	20 (198)	150	–	–	125	23	60	53	66	21,8	RT-2111
4661	126 (1237)	170	51 (496)	170	20 (198)	160	200	34	90	83	100	67,3	RT-2119
2359	81 (792)	150	32 (309)	150	–	–	160	25	80	66	89	39,9	RT-3311
8816	202 (1985)	200	81 (792)	200	32 (309)	200	250	44	110	111	123	124,0	RT-3323